

F120A (Series 2), Room Air Cleaning System

PRODUCT DATA



GENERAL

The F120 Room Air Cleaning System is designed to collect particles by circulating room air through a media filter. When equipped with an optional CPZ module, the system also adsorbs gaseous contaminants and odors.

The F120 exhaust feature is used to maintain the space at a negative pressurization relative to adjacent spaces to prevent contaminants and odors from moving into nearby areas.

The air supply and return design of the F120 allows air contaminants to be filtered at the center of the room with the filtered air returned toward the sides of the room for maximum room air cleaning.

FEATURES

- Specifically designed for use in offices, hospitals, medical clinics, childcare centers, schools, conference rooms, copy centers, laboratories, cafeterias, and hospitality business.
- Ultra-quiet operation allows the system to be used in sound sensitive areas such as conference rooms, offices, classrooms and libraries.
- Modular design of air supply and return allows maximum flexibility when planning the appropriate air recirculation pattern to maximize overall system performance.
- Special return module filter removes both particulates and gaseous contaminants from the air stream.
- Convenient roomside service for all filters.
- Easy-to-change prefilter extends the media filter life.
- Blower module can be mounted remotely from the room to further reduce sound levels.
- Three-speed fan motor allows selecting high, medium or low airflow speeds. Includes 3-speed wall mount switch.
- Optional exhaust feature allows installations to maintain the space at a negative pressure with respect to surrounding areas to prevent contaminants and odors from moving into nearby areas.
- Installation is ideally suited to rooms with either two-by-four or two-by-two foot drop ceiling panels, but can be installed in any wall or ceiling that allows ducting space.

Contents

General	1
Features	1
Specifications	2
Ordering Information	2
Planning the Installation	3
Installation	7
Operation	13
Maintenance	13
Parts List	14



SPECIFICATIONS

IMPORTANT

The specifications given in this publication do not include normal manufacturing tolerances. Therefore, this unit may not exactly match the listed specifications. This product is tested and calibrated under closely controlled conditions, and some minor differences in performance can be expected if those conditions are changed.

Model:

F120A consists of:

- two filtered return modules with a return grille, prefilter, and
- either a 99.97% HEPA filter or 95% DOP (MERV 16) filter with CPZ module;
- Air supply modules with supply grilles;
- blower module with a three-speed blower, four recirculating air supply openings four recirculating air return openings and an optional exhaust opening;
- a 3 speed wall mount switch
- mounting hardware kit consisting of 12 mounting brackets; 40 ft (12m) of 12-gauge high-tensile strength wire; six standard T- bar mounts;

Color:

Blower Housing: Unpainted galvanized steel.
 Return Modules: Off-white
 Supply Grilles: Off-white

Filters:

HEPA: High efficiency particulate air (HEPA) filter is 99.97 percent efficient for 0.3 micron particulates when measured with Military Standard 282 DOP test.
 DOP: Hospital-grade DOP filter is 95 percent efficient for 0.3 micron particulates (MERV 16) when measured with Military Standard 282 DOP test (MERV 16).
 CPZ: Sorbent modules contain 11 pounds of sorbent. Adsorbs higher molecular weight hydrocarbons and oxidizes acid gases and lower molecular weight hydrocarbons.

Air Flow Capacity:

Model	Voltage	Number of Return & Supply Modules	Media Filter Efficiency	Gas, VOC, Odor Control Module (2)	Air Flow in cfm (m ³ /hr)		
					HIGH	MEDIUM	LOW
F120A 1023	120 VAC/ 60 Hz	Return: 2 Supplies: 4	95% D.O.P. (at 0.3 microns) (MERV 16)	CPZ	925 (1572)	725 (1232)	525 (892)
F120A 1031			HEPA (99.97% D.O.P. at 0.3 microns)	—	950 (1615)	725 (1232)	475 (807)

Shipping Weight:

F120A with 95% DOP Filter and CPZ Module: 207 lb (94 kg).
 F120A with 99.97% HEPA Filter: 182 lb (83 kg).

Dimensions:

See Fig. 1.

Ambient Temperature Rating:

Shipping and Storage: -20°F to +150°F (-29°C to +66°C).
 Operating: Ambient temperatures ≥90°F (32°C).
 Can tolerate 104°F (40°C) for brief periods.

Sound Output Rating at 3.3 ft (1m):

High Speed: 52 dBA (below ASHRAE noise criteria (NC) curve specifications for NC45 over speech recognition frequency range of 500 to 2000 Hz).
 Medium Speed: 48 dBA (below ASHRAE noise criteria (NC) curve for NC35 over speech recognition frequency range of 500 to 2000 Hz).
 Low Speed: 43 dBA (below ASHRAE noise criteria (NC) curve for NC35 over speech recognition frequency range of 500 to 2000 Hz).

Installation Weight:

Blower Module: 63 lb (28.6 kg).
 Supply Module: 8 lb (3.6 kg).
 Return Module /no filter: 24 lb (10.9 kg).
 95% DOP (MERV 16) Filter/CPZ Module: 24 lb (9.5 kg).
 99.97% HEPA Filter: 10 lb (4.5 kg).

Electrical Ratings:

F120A	120 Vac, 60 Hz		
	Fan Speed		
	HIGH	MEDIUM	LOW
Current (A)	7.0	6.0	4.2
Power (W)	880	760	525

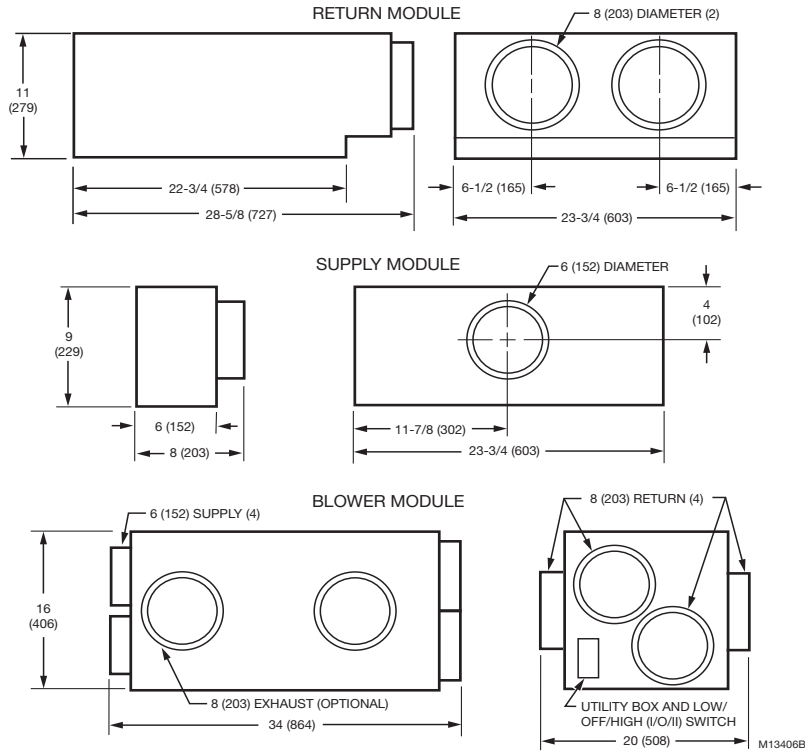

Fig. 1. Approximate F120A dimensions in inches. (mm).

PLANNING THE INSTALLATION

The F120 Room Air Cleaning System is designed for use in offices, hospitals, medical clinics, childcare centers, schools, conference rooms, smoking rooms, copy centers, laboratories and cafeterias.

The quiet design allows the system to be used in sound sensitive areas such as conference rooms, offices, classrooms, and libraries where other air cleaning systems may be too noisy.

Determining F120 Size

Use the sizing procedure to determine how many F120s are needed. The correct number for a particular application depends on:

- type of contaminant.
- number of occupants.
- room volume.
- room use.
- outdoor air quality.

1. Select the fan speed to be used for the application as the normal operating speed. Select the speed according to the sound sensitivity level appropriate for the application (if the application requires an especially quiet operation, low speed sizing is recommended):
 - a. High speed – the sound output is below the ASHRAE NC-45 noise criteria curve over the speech frequency range of 500 to 2000 Hz.
 - b. Medium speed – the sound output is below the ASHRAE NC-40 curve over the speech frequency range of 500 to 2000 Hz.
 - c. Low speed – the sound output is below the ASHRAE NC-35 curve over the speech frequency range of 500 to 2000 Hz.
2. Determine if the room requires optional exhaust feature to prevent the migration of contaminants to other areas. (This F120 feature is used to maintain the controlled space at a slightly negative pressure.)

WARNING

Combustion Hazard.

Installing combustion appliances in same space as F120 System can cause backdrafting and hazardous gas accumulation.

Consult combustion appliance manufacturer installation instructions to determine appropriate installation location.

3. Identify the types of contaminants to be controlled. For particulates only, use the F120 with a 99.97% HEPA or 95% DOP. To control odors and gaseous contaminants (for example, smoking rooms), use the F120 with a CPZ module along with the Media filter.
4. Use the airflow ratings in the Specifications section to determine the number of F120s needed.
 - a. Size the air cleaning system using either air changes per hour (ac/h) or occupant load. See ASHRAE Standard 62-1999, Ventilation for Acceptable Indoor Air Quality, for the outdoor air requirements. (Use the clean recirculated F120 air for a portion of the recommended values.)
 - b. When calculating the system requirements, consider factors such as architectural features, lighting fixtures, sprinkler systems, HVAC air ducts, and grilles in the room.

Example 1: Sizing By Occupant Load

A cocktail lounge averages 75 occupants. How many F120 should be installed?

Solution:

$$\text{F120 required} = \frac{\text{ASHRAE clean air per person} \times \text{occupants}}{\text{F120 airflow capacity}}$$

ASHRAE recommends 30 cfm per person clean air for cocktail lounges. Operating the F120 on high speed with the a 95% ASHRAE filter with CPZ filter, the airflow capacity is 1025 cfm.

Calculation:

$$\begin{aligned} \text{Number of F120 required} &= \frac{30 \text{ cfm per person} \times 75 \text{ people}}{1025 \text{ cfm}} \\ &= \frac{2250 \text{ cfm}}{1025 \text{ cfm}} = 2 \text{ units} \end{aligned}$$

Minimal outside air is required.

Outside Air Calculation:

$$15 \text{ cfm per person} \times 75 \text{ people} = 1125 \text{ cfm.}$$

Example 2: Sizing By Air Changes Per Hour (Ac/h).

A restaurant measures 40 x 45 feet with a 12 foot ceiling. How many F120 should be installed?

Solution:

$$\text{F120 feet required} = \frac{\text{desired air circulation (cfm)}}{\text{F120 airflow capacity}}$$

Without considering other data, select the correct number of F120 units that provides between 8 and 12 ac/hr. This example uses 10 ac/hr. Operate the F120 on high speed with a 95 percent ASHRAE filter and CPZ; the airflow capacity is 1025 cfm.

Calculation:

First determine the volume of the space:

$$\text{Volume} = 40 \times 45 \times 12 = 21,600 \text{ cubic feet.}$$

Then determine the volume of air to be circulated.

$$21,600 \text{ cu ft} \times 10 \text{ ac/hr} = 216,000 \text{ cfh or}$$

$$\frac{216,000 \text{ cfh}}{60 \text{ min/hr}} = 3600 \text{ cfm}$$

$$\text{F120 required} = \frac{3600 \text{ cfm}}{1025 \text{ cfm}} = 3 \text{ units}$$

Minimal outside air is required.

Outside Air Calculation:

Provide air equal to 15 cfm/person.

Example 3: Designated Smoking Room

In buildings where smoking is banned in the general office area but segregated to an enclosed designated smoking room with its own ventilation system exhausted to the outside, what is needed?

Solution:

F120 with a 95 percent DOP filter, a CPZ module is the perfect solution for designated smoking rooms.

The F120 is specifically designed to maintain an acceptable comfort level for the occupants in rooms with up to fifteen smokers on High speed and up to twelve smokers on Low speed.

Provide minimal outside air. Supply fresh air to the room through a door grille or an outside duct.

Outside Air Calculation:

Allow 15 cfm per person.

Choosing the Location

The modular design of the F120 allows maximum flexibility to optimize the airflow pattern when selecting locations for the blower module, return modules, and supply modules.

1. Plan the position of the return and the supply modules so the airflow can reach the farthest area of the space:
 - a. Mount the return modules up to 20 ft (6m) and the supply modules up to 12 ft (3.5m) from the blower module (longer duct runs can be used with reduced airflow).
 - b. Mount the return modules in the center of the area with two supply modules installed on each side. See Fig. 2.
 - c. With multiple F120 in a room, distribute them equally throughout the space by dividing the entire space into equal volumes. See Fig. 3.
 - d. To use the F120 to divide a large area into smoking and non-smoking sections, mount the return modules on one side of the smoking area and place the supply modules along the dividing line between the two sections. Use the exhaust option to help keep the smoke out of the non-smoking section. See Fig. 4
2. Examine the space above the drop ceiling for obstructions, such as piping for sprinkler systems, HVAC ducting or electrical wiring for the lighting system, that can interfere with installing the F120.
3. Decide where to mount the F120 modules:
 - a. Hang the blower module from the structural ceiling above the drop ceiling (minimum of 17 in. is required).
 - b. Allow a minimum of 16 in. clearance on all four sides for the flexible ductwork.
 - c. For the return and supply modules, allow a minimum of 12 in. clearance between the drop ceiling and the structural ceilings, with clearance on one side for duct access.
4. If the exhaust feature is used with the F120A, determine the location of the exhaust discharge. If the discharge is more than 50 ft. from the blower module, use an optional booster blower to achieve adequate exhaust airflow.
5. For optimum performance of each F120 System:
 - a. Use the sizing formulas to determine the number of F120 required for the larger room.
 - b. Visually divide the entire room into several cubic volumes. For example, if three F120 are planned, visualize the room as three roughly equal cubic volumes.
 - c. Consider each cubic volume as a single room, and install the return modules at the center of each area with the supply modules on the periphery.
 - d. Draw an installation layout diagram showing the location of the blower, return and supply modules, and the exhaust outlet (optional). Use this diagram later during the air cleaning system installation.

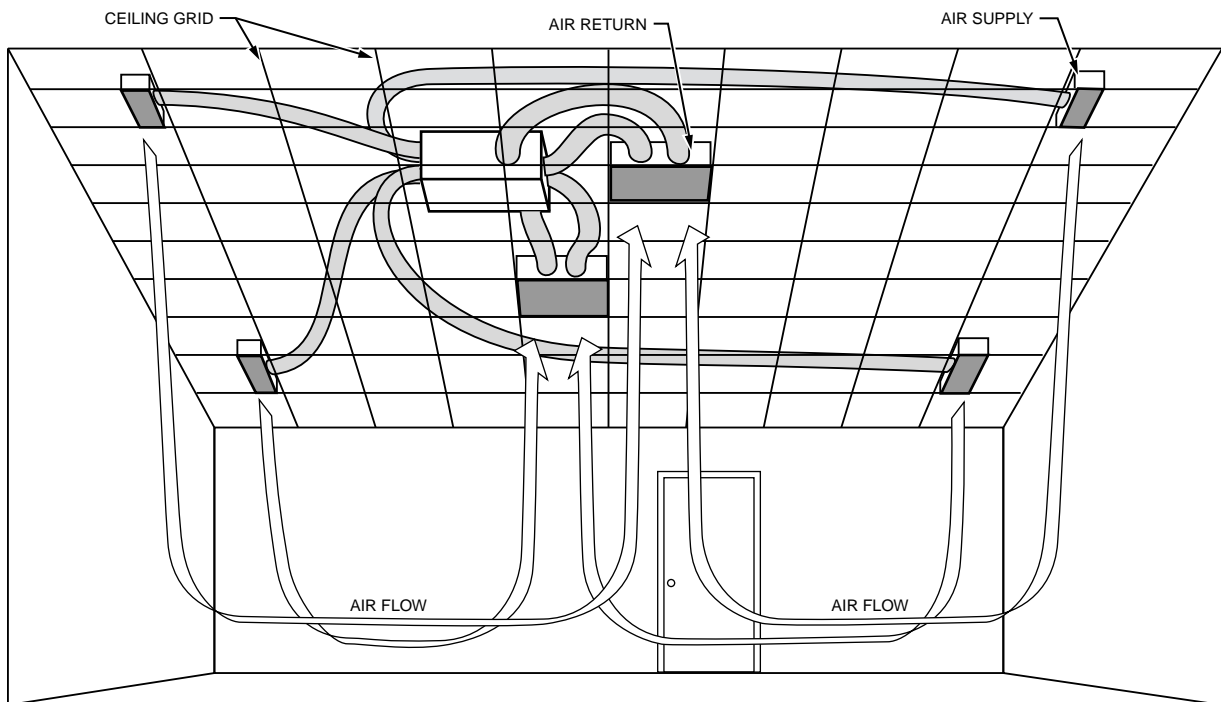

M13407

Fig. 2. Mounting F120A.

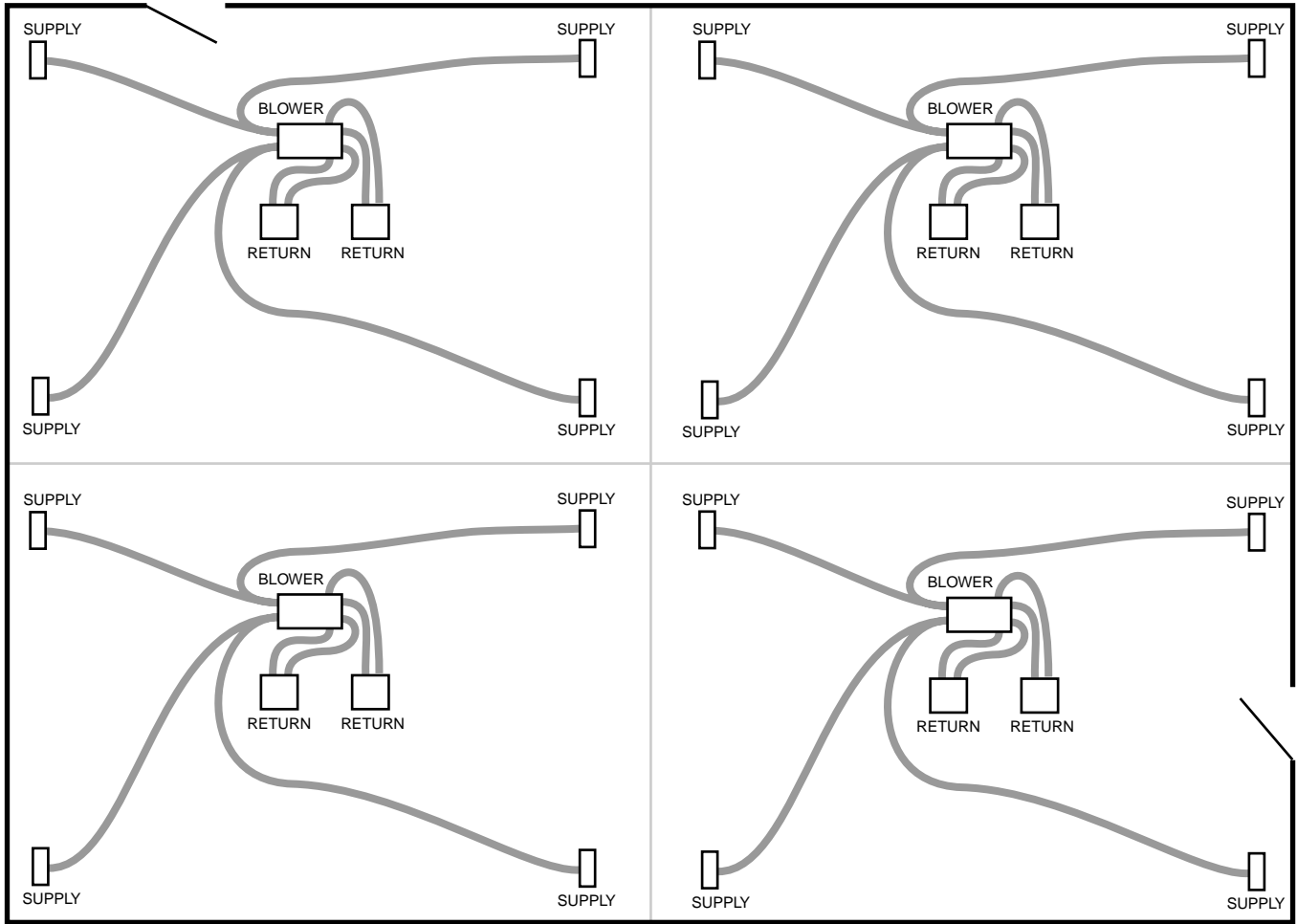

M13408

Fig. 3. Installing multiple F120A.

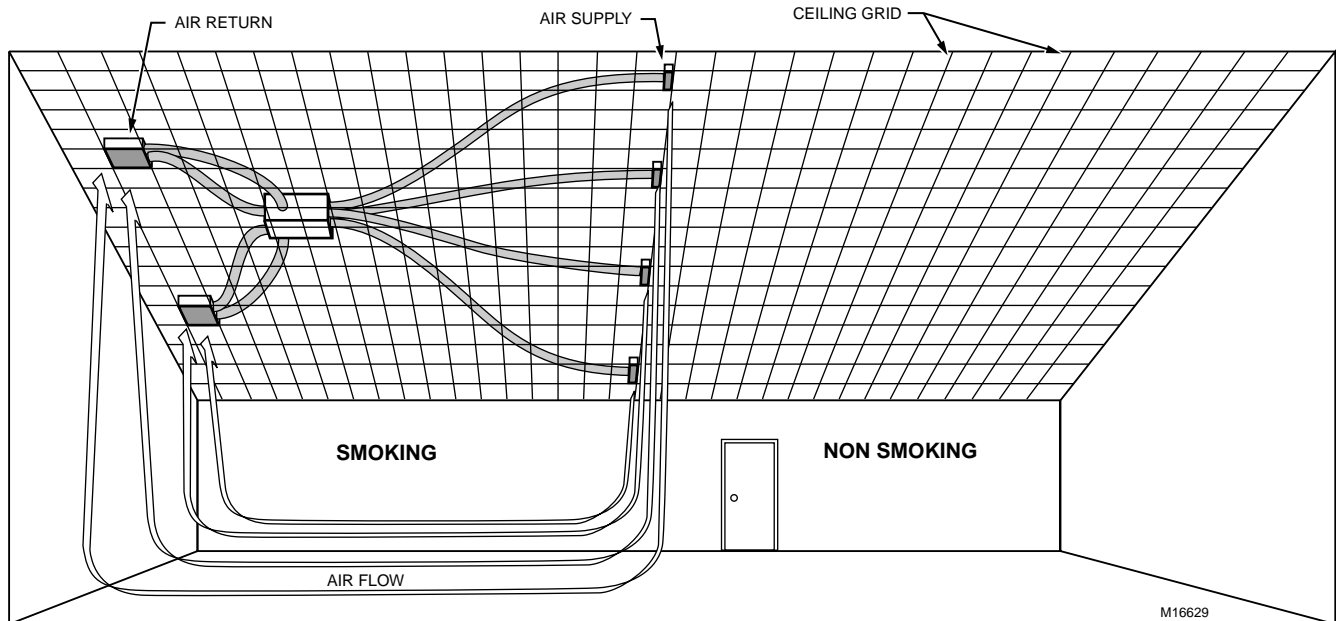

M16629

Fig. 4. Dividing a large area into smoking and non-smoking sections.

INSTALLATION



WARNING

Explosion Hazard.

Can cause personal injury or equipment damage. Do not install or use the F120 Room Air Cleaning System where there is any danger of gas, vapor or dust explosion.

Do not install when explosion-proof electrical fixtures are specified.

Canadian Installation: Do not use in ceilings where fire-resistant assemblies are specified.



WARNING

Fire or Electric Shock Hazard.

Can cause personal injury or equipment damage. Turn off power source before installing or servicing the air cleaning system.

When Installing this Product...

1. Read these instructions carefully. Failure to follow them could damage the product or cause a hazardous condition.
2. Check the ratings given in the instructions and on the product to make sure the product is suitable for your application.
3. The installer must be a trained, experienced service technician.
4. After installation is complete, check out product operation as provided in these instructions.

Unpacking Air Cleaning System



CAUTION

Personal Injury Hazard.

Sharp metal edges on components of air cleaning system can injure hands and fingers.

Wear protective gloves and carefully handle system components to avoid cuts from sharp metal edges.

Preparing F120A Air Cleaning System for Installation

1. Unpack, identify and inventory all parts:
 - Literature.
 - Mounting hardware kit: 12 mounting brackets, 40 ft (12 m) of 12-gauge high tensile strength wire, six 2-ft (0.6) drop-ceiling T-bar mounts.
 - Two return modules with grilles.
 - 3-speed wall switch/controller
 - Four supply modules with grilles.
 - Two high-efficiency filters $\frac{3}{4}$ either HEPA, DOP, or ASHRAE and CPZ modules.
 - One package (12) prefilters.
 - Blower module.
2. Remove all shipping cardboard, plastic and containers from the system parts.
3. Locate additional items required for the installation (not included) that the installer provides:
 - a. External hardware such as extra nuts and bolts secure the mounting wire or chain to the ceiling.
 - b. Leveling tool.
 - c. Drop-ceiling T-bars (4) two-feet (0.6m) long if grids supplied do not match the grid system.

Preparing Area for Installation

1. Refer to the installation diagram for locations of the blower, return and supply modules and remove ceiling panels from those locations.
2. Verify the required clearance between the drop and structural ceilings:
 - blower module clearance of 17 in. (430 mm); 16 in. (400 mm) clearance is required on all four sides for ductwork.
 - return module clearance of 12 in. (304 mm).
 - supply module clearance of 10 in. (205 mm).
 - clearance for ductwork.
 - 6 in. (150 mm) diameter between blower and supply modules.
 - 8 in. (200 mm) diameter between blower and return modules.
 - clearance for exhaust duct.

Installing F120A Blower Module

1. Prepare blower module to mount entirely above the drop ceiling.
2. Mark the location for the mounting bolts in the structural ceiling. See Fig. 5.
3. Install the mounting bolts in the structural ceiling.

! WARNING

Fire and Electric Shock Hazard.
Can cause personal injury or equipment damage.
 Wait to connect the power source to the blower module after securely mounting in the ceiling.

4. Locate the multiple slots on the blower module for mounting the support shoulder mounting brackets. See Fig. 5.
5. Insert the brackets into the selected slots.
6. Thread the wire through the brackets. Do not rest the blower module on the T-bar unless it is reinforced to hold the weight.
7. Twist the support wire a minimum of four times.

! CAUTION

Personal Injury or Equipment Damage Hazard.
Equipment can fall and injure installer or become structurally weakened, buckled or damaged.
 Verify platform is stable and can bear combined weight of installer and equipment.

Seek installation assistance to prevent return module from accidentally falling or dropping.

8. Standing on a secure platform, lift the module and raise it up above the drop ceiling.
9. Attach the free ends of the support wires to the bolts mounted in the structural ceiling.
10. Check the wire to observe that it supports the blower module.
11. Level the blower module.

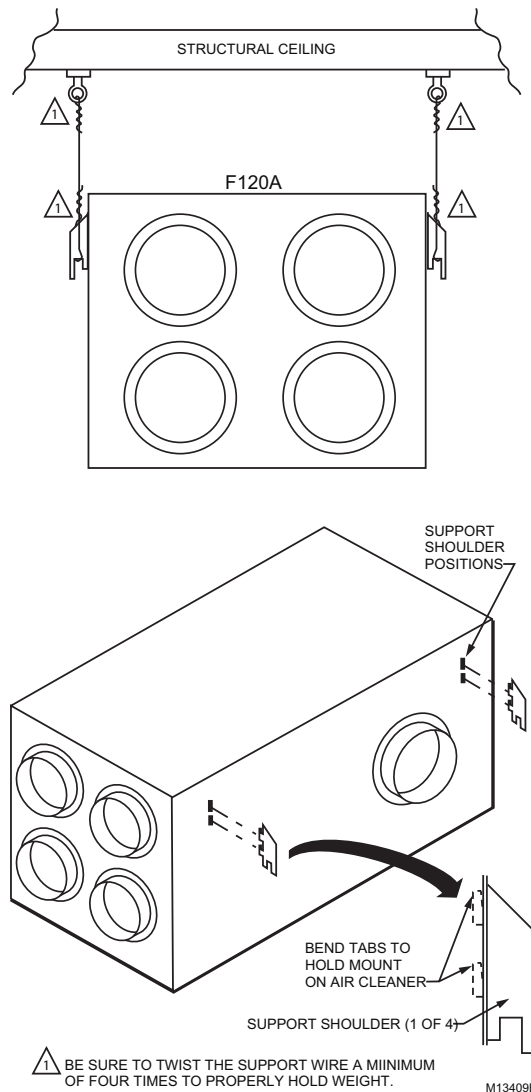

Fig. 5. Installing F120A blower module mounting bolts.

Installing F120A Return Module

1. The return module mounts level with the drop ceiling T-bars. Mark the location for the mounting bolts in the structural ceiling. See Fig. 6.
2. Install the mounting bolts in the structural ceiling.
3. Locate the return module slots for mounting the shoulder support mounting brackets.
4. Insert the brackets into the selected slots.
5. Orient the return module so the duct collars are pointing correctly.
6. Thread the wire through the support shoulders. Do not rest the blower module on the T-bar unless it is reinforced to hold the weight.
7. Twist the support wire a minimum of four times.

⚠ WARNING

Personal Injury or Equipment Damage Hazard. Equipment can fall and injure installer or become structurally weakened, buckled or damaged.
 Verify platform is stable and can bear combined weight of installer and equipment.
 Seek installation assistance to prevent return module from accidentally falling or dropping.

8. Standing on a secure platform, lift the module and insert it into the drop ceiling opening level with the T-bars.
9. Attach the free end of the support wire to the bolts mounted in the structural ceiling.
10. Level the return module.

NOTE: If installed in a 2 x 4-foot ceiling grid, use the two-foot T-bar provided to trim the return grille. Resize the drop ceiling panel, if necessary, to fit.

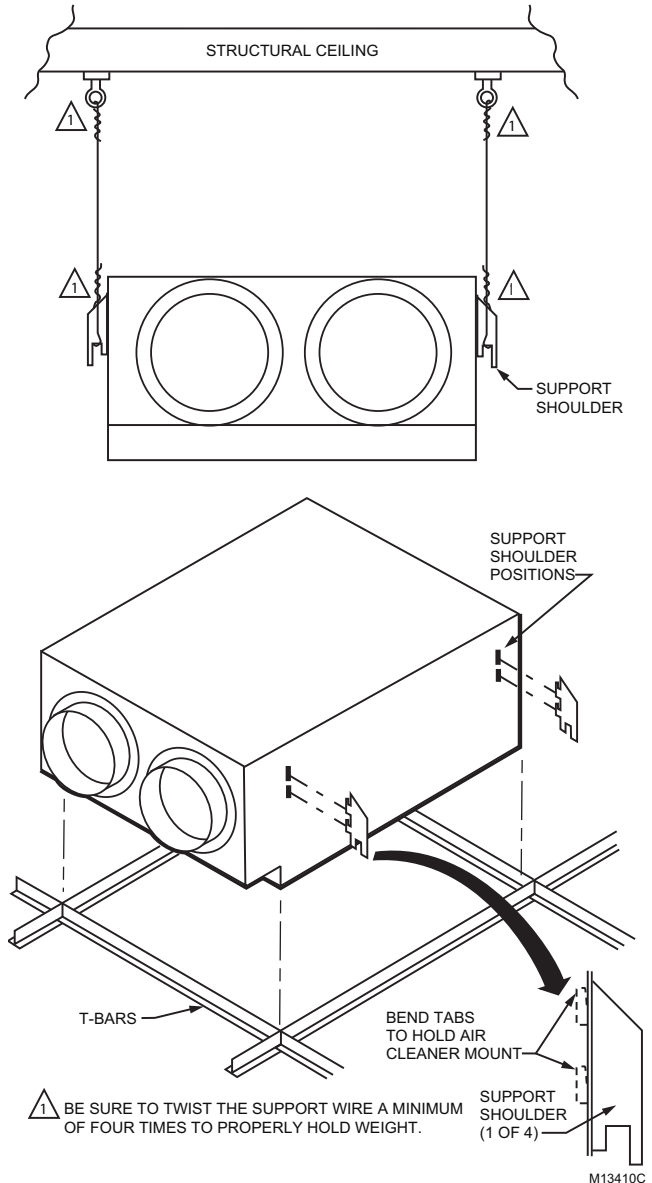

Fig. 6. Installing F120A return module.

Installing Supply Module

The supply modules are mounted directly on the drop-ceiling T-bars. Orient the modules so the duct collars are pointing correctly for easy duct attachment. See Fig. 7.

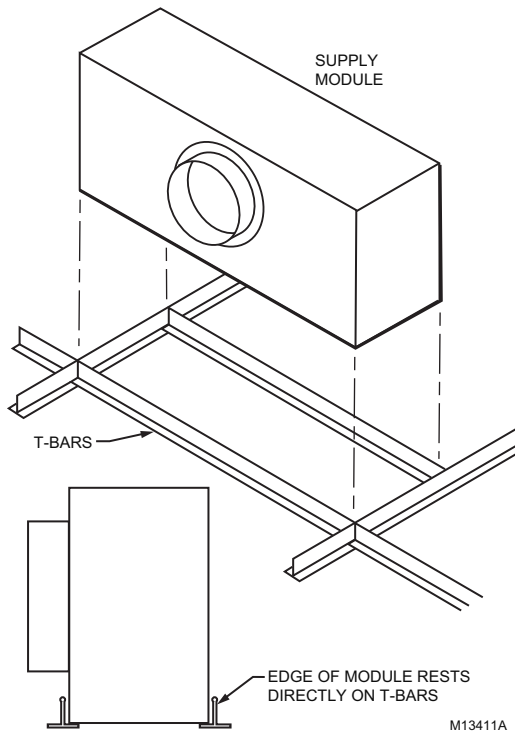

Fig. 7. Mounting supply modules.

1. Mount the modules directly on the drop ceiling T-bar.
2. Install the two-foot T-bar.
3. Resize the drop ceiling panel to fit.
4. Install the grille by inserting it into the supply module and letting it rest on the T-bar.

Installing Ductwork F120A

The F120 System requires 6 in. diameter ducting (not included) to connect the four supply modules to the blower module. It also requires 8 in. diameter ducting (not included) to connect the two return modules to the blower module. Flexible ducting is acceptable to use.

1. Measure the 6 in. diameter duct lengths (distance between blower and supply module 6 in. diameter collars).
2. Cut the ducting to the correct lengths.
3. Install the 6 in. ducting between the blower and the supply modules.
4. Use duct tape and straps to secure the flexible ducting to the collars.
5. Measure the 8 in. diameter ducting lengths (distance between blower and return module 8 in. diameter collars).
6. Cut the ducting to the proper lengths (two 8 in. diameter ducting are required for each return module).
7. Install the 8 in. ducting to the blower module and to the return modules.
8. Secure the flexible / ducting to the collars.
9. If using the F120 room exhaust feature, measure the length from the blower exhaust to the exhaust outlet.
10. Attach the exhaust ducting to the blower exhaust using duct tape and straps.

Wiring

The F120 has a standard 2 x 4 in. (50 x 100 mm) electrical box for field wiring. The field-wiring compartment is located on the return end of the blower module.

IMPORTANT

All wiring must comply with applicable codes and ordinances. Check that the air cleaner is grounded for proper operation and safety.

Canadian installation: Do not install in ceilings with thermal insulation value greater than R-40.

1. Use the appropriate knockout to run the electrical wiring into the box.
2. Connect the electrical wiring as shown in Fig. 8.

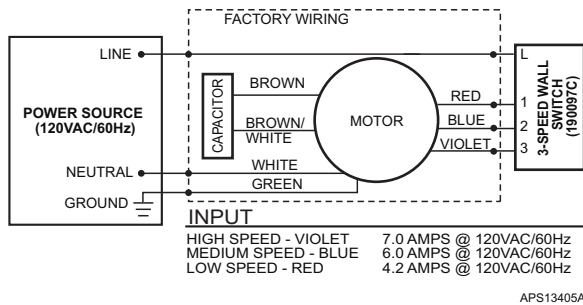

Fig. 8. F120A Series 2.

WARNING

Electric Shock Hazard.

Can cause personal injury or equipment damage. Be extremely careful to avoid electrical shock during operation checkout.

Be extremely careful when working near moving parts.

3 Speed Wall Switch (F120 Series 2)

The Wall Switch Assembly allows control of the F120 model air cleaners from a location separate from the air cleaner. The assembly includes a 3 speed wall switch with an outlet box cover, outlet box, extension ring, and a wire harness. Wiring to connect the wall switch and air cleaner must be furnished separately.

CAUTION

- This installation to be performed only by a qualified installer.
- All wiring to comply with local electrical codes.
- Disconnect power to air cleaner at fuse or breaker before beginning work. Failure to do so can result in shock hazard endangering equipment and personal safety of installer.
- Only one air cleaner can be connected to a 3 speed wall switch

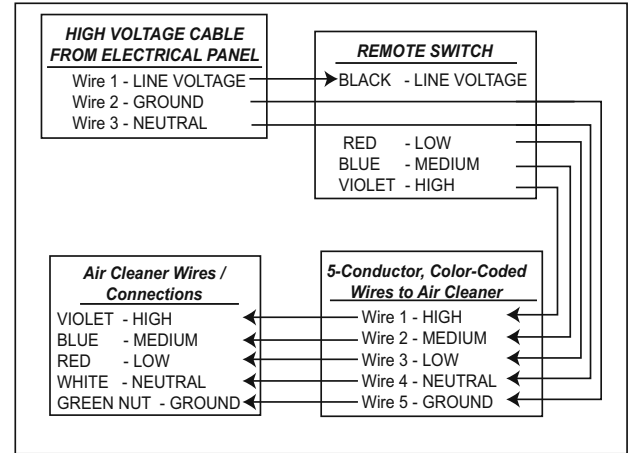

Fig. 9. Wiring F111 Series 3 Air Cleaner

1. Disconnect power to air cleaner.
2. Mount 4" x 4" outlet box at desired wall location.
3. Attach 3/4" extension ring to outlet box.
4. Run five conductor, color-coded, 18-gauge wires from the wall switch location to the air cleaner.

At WALL SWITCH :

5. Use three wire nuts to connect three color-coded, wires on the wall switch to three color-coded wires running to the air cleaner. (Red [1], Blue [2], Violet [3])
6. Use one wire nut to connect white color-coded, wire running to the air cleaner to the Neutral wire from the power source/electrical panel. (White)

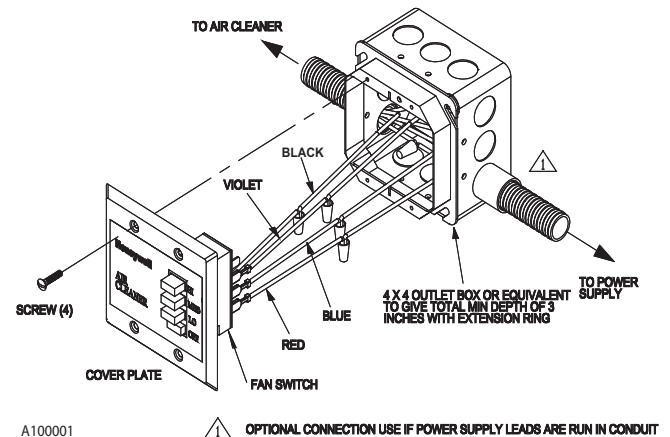

Fig. 10. Wiring 3-Speed Wall Switch

7. Connect the ground wire from the power source / electrical panel to the ground stud of the outlet box.(Green)
8. Connect the ground wire from the air cleaner to the ground stud of the outlet box.(Green)
9. Use one wire nut to connect the black color-coded, lead wire on the wall switch [L] to the black color-coded wire from the power source/electrical panel.
10. Fold wires into box and mount wall switch on outlet box. Leave switch in OFF position.

At AIR CLEANER :

11. On the air cleaner remove two screws on wiring compartment cover and open

12. Run the five conductor, color coded, 18 gauge wires from the wall switch through the air cleaner access opening into the wiring compartment. Strip ends of these lead wires.
13. Connect three wires from air cleaner to wall switch lead wires with wire nuts following color code used at wall switch. (Red, Blue, Violet)
14. Connect the white wire on air cleaner to power source/electrical panel Neutral wire with a wire nut following color code used at wall switch. (White)
15. Connect the ground wire from the wall switch to a ground stud of the wiring compartment cover.(Green)
16. Fold wires into wiring compartment. Replace wiring compartment cover.
17. Turn on power to air cleaner at power source/electrical panel.
18. Check operation by turning ON air cleaner by selecting HIGH, MEDIUM, or LOW. Test all 3 speeds. Note that only the wall switch will operate the air cleaner.

Installing Filters

The F120 offers 2 types of filter combinations:

- 99.97% HEPA.
- 95% DOP with CPZ module

All filters are installed the same. See Fig. 11.

IMPORTANT

Wear safety goggles when installing or removing the overhead CPZ™ modules to avoid contact with dust released during normal handling.



CAUTION

Equipment Damage Hazard.

Can damage filter frame or filter media.

Avoid touching pleated filter media.

Handle only the filter frame.

1. Remove filters from plastic wrapper.
2. Be sure front of filter assembly rests on filter support hooks in return module.
3. Make sure airflow direction arrow is pointing toward top of return module and the filter eye hook faces out.
4. Carefully lift the filter and hook frame onto the support hooks.
5. Swing the filter into the unit and latch the filter frame securely to the module by inserting the module hook through the eye bolt on the filter.

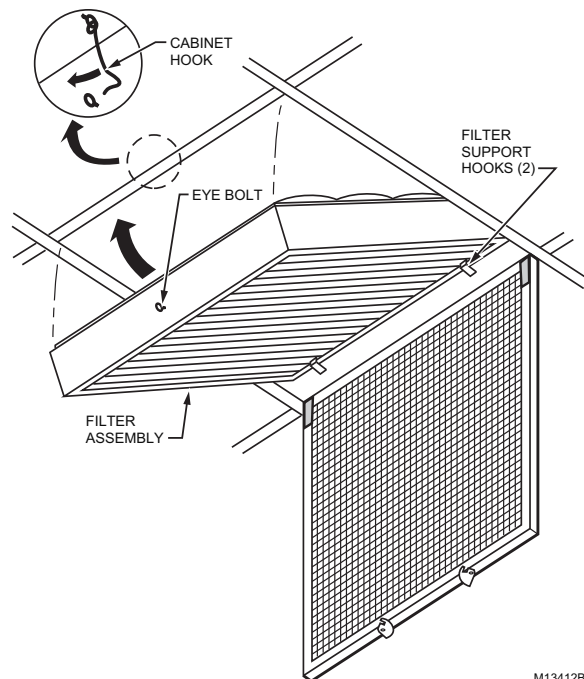

M13412B

Fig. 11. Installing F120 filters.

Installing Grille and Prefilter

When installing, allow space for pulling down the grille a radius of two feet to open it. Be sure it can open freely without obstruction.

1. Install the grille by inserting the grille hinge hooks into the opening in the return module. Be sure the grille hangs freely from the cabinet. See Fig. 12.
2. Install the prefilter by pressing the filter onto the velcro fasteners at the top of the hanging grille. See Fig. 12.
3. Swing the grille up into the cabinet and rotate the two latches closed.

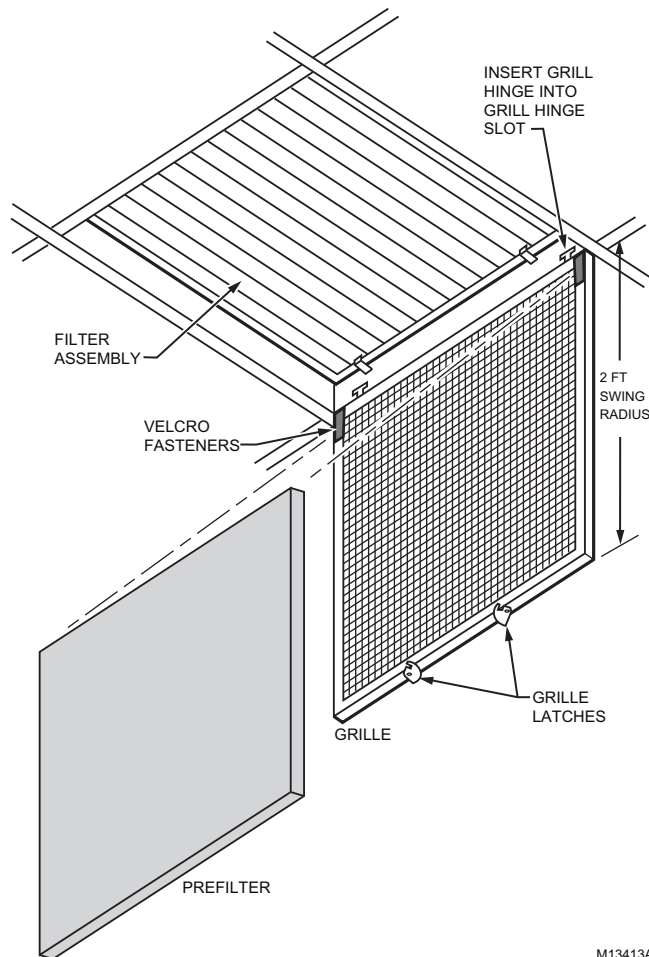

Fig. 12. Installing grille and prefilter.

OPERATION

The F120 System is engineered to improve indoor air quality for commercial applications. The filters effectively capture atmospheric dust, mold spores, smoke, fumes, mists and aerosols.

Air cleaning systems and ventilators use filtration or dilution to reduce excessive accumulation of contaminants. To eliminate airborne contaminants, the source must be removed.

Ventilation standards and codes specify minimum ventilation rates to dilute air contamination for specific applications. The rates assume a fresh outdoor air exchange.

Using the F120 to comply with ventilation requirements is an acceptable alternative to ventilation with outdoor air. It is recommended that a minimum of 15 cfm per person outdoor air be provided.

MAINTENANCE

The F120 Room Air Cleaning System is designed with a dual filter to allow longer intervals between maintenance. Regular maintenance of the prefilter and filter assembly can be done easily without special tools:

1. Remove and replace the Media filter, which collects smaller particles not collected by the prefilter. (Washing, vacuuming and reverse air blasting the filter are not effective.) The filter lasts 12 to 24 months, depending on facility occupancy factors.
2. Change the disposable prefilter after every one to two months of operation.
3. Replace the CPZ Module every four to 24 months, depending on the application, when the adsorbent emits a continuously strong pungent odor.

NOTE: When tobacco smoke is the contaminant, replace both the media filter and the CPZ module at the same time.

Replacing the filter

1. Open the two grille latches by swinging down the grille.
2. Remove the dirty prefilter from the velcro holders.
3. Unhook the filter assembly and swing it out of the unit.
4. Lift the filter assembly from the installation hooks and place it on the floor.
5. Install the filter assembly by positioning it on the installation hooks with the air flow arrows pointing up to the unit.
6. Replace the prefilter pad by attaching it to the velcro holders.
7. Swing the grille into the unit and close the latches.

PARTS LIST

See Fig. 13 for exploded view of F120.

Item No.	F120A Part No.	Description
1		Return Module F120A (without filters)
2	32003983-001	Prefilter (12 pack)
3		Return Grille Assembly, Metal, Aluminum
5	32003985-001	95% DOP Filter (MERV 16)
6	32003986-001	99.97% HEPA Filter
7	32003987-002	CPZ Module
8		CPZ Module Frame
9		Blower
10		Motor, 3 Speed
11		Blower Module, 3 Speed Motor, 6"/8" Dia.
12		Supply Module with Grille
13		Supply Grille
14		Motor Capacitor

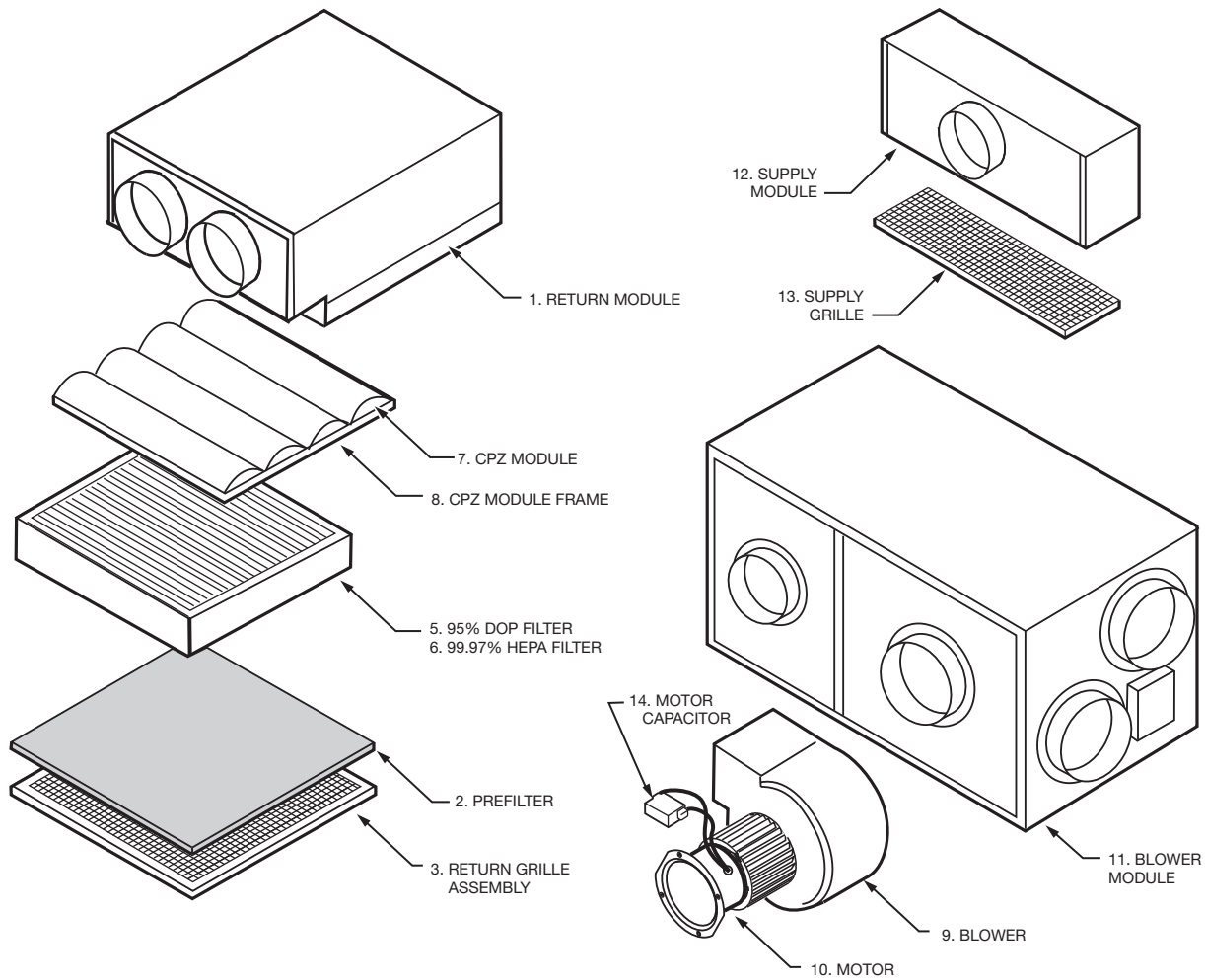

M13414A

Fig. 13. F120A exploded view.

Honeywell Building Technologies

In the U.S.:

Honeywell

715 Peachtree Street NE

Atlanta, GA 30308

customer.honeywell.com

buildingcontrols.honeywell.com

Honeywell